



FA CUP

2025/26

**足總盃
賽事章則**

**FA Cup
Competition Regulations**



FA CUP



1974/1975 Seiko	1991/1992 Ernest Borel	2008/2009 Tai Po
1975/1976 Seiko	1992/1993 Eastern	2009/2010 TSW Pegasus
1976/1977 Rangers	1993/1994 Eastern	2010/2011 South China
1977/1978 Seiko	1994/1995 Rangers	2011/2012 Kitchee
1978/1979 Yuen Long	1995/1996 South China	2012/2013 Kitchee
1979/1980 Seiko	1996/1997 Instant-Dict.	2013/2014 Eastern
1980/1981 Seiko	1997/1998 Instant-Dict.	2014/2015 Kitchee
1981/1982 Bulova	1998/1999 South China	2015/2016 Hong Kong Pegasus
1982/1983 Bulova	1999/2000 Happy Valley	2016/2017 Kitchee
1983/1984 Eastern	2000/2001 Instant-Dict.	2017/2018 Kitchee
1984/1985 South China	2001/2002 South China	2018/2019 Kitchee
1985/1986 Seiko	2002/2003 Sun Hei	2019/2020 Eastern
1986/1987 South China	2003/2004 Happy Valley	2020/2021 —
1987/1988 South China	2004/2005 Sun Hei	2021/2022 —
1988/1989 Lai Sun D' Flower	2005/2006 Sun Hei	2022/2023 Kitchee
1989/1990 South China	2006/2007 South China	2023/2024 Eastern
1990/1991 South China	2007/2008 Citizens	



賽事命名

1. 本賽事命名為「2025/26足總盃」。中國香港足球總會(本會)保留增加冠名贊助，或將整項賽事名稱轉為贊助商名稱的權利。

賽事管理

2. 本賽事由中國香港足球總會全權管理。

基本條款

3. 除於本章則有另文規定外，否則將依循2025/26香港超級聯賽賽事章則執行。
4. 除非於本章則中另外註明，否則各參與賽事之人士(包括但不限於球員、球隊職員、裁判員或賽事工作人員等)皆須受到現存中國香港足球總會憲章、條例、規章、守則、指引、通告或指令所約束。

參賽資格

5. 凡為2025/26香港超級聯賽之參賽球會均須參加足總盃。任何球會不可以派出超過1隊參加。本會董事會有權因應賽事組成，邀請本地或海外球會參與本賽事。
6. 在獲得三分之二多數出席董事通過的情況下，本會董事會可否決任何球會參加本賽事。

賽事組織

7. 參賽球會必須派出實力最強之隊伍出賽，否則必須具備理由，呈報中國香港足球總會秘書處。
8. 賽事採取單淘汰賽形式進行(請參閱下圖)。參賽球隊之第一場比賽對賽將以抽籤形式決定。2024/25年度足總盃晉身準決賽之球隊將列為種子隊伍，直接晉身半準決賽階段，而種子隊伍將不會於半準決賽階段與另一支種子隊伍對賽。

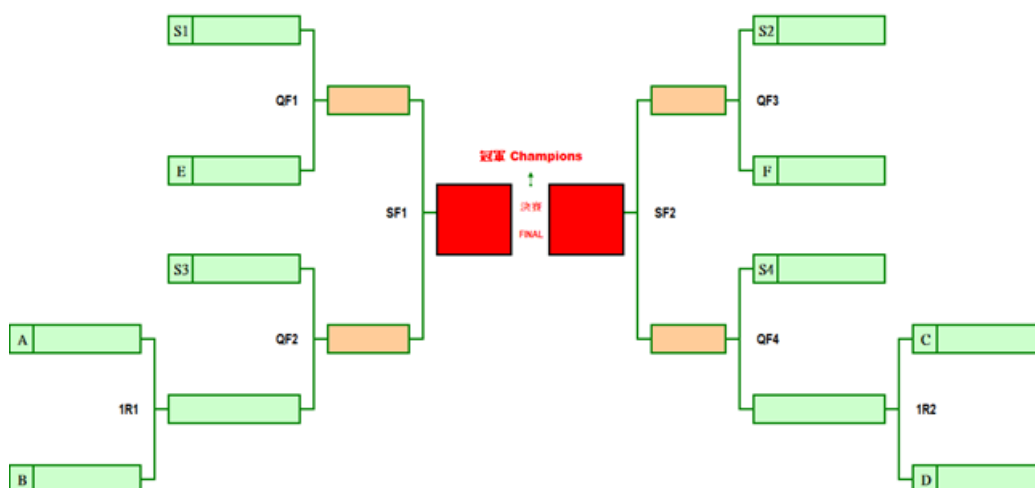

9. 每場比賽時間為90分鐘，分為上、下半場各45分鐘，中場休息不多於15分鐘。如法定時間90分鐘內賽和，將會進行上、下半場各15分鐘加時賽，如加時比賽後仍然賽和，比賽將根據球例 (Laws of the Game) 中所規定之互射點球方法來決定勝負。
10. 每場比賽每支球隊之替換球員安排如下：
 - 10.1 每支球隊最多可替換5名球員；
 - 10.2 每支球隊最多可有3次替換球員機會(如果兩支球隊同時作出替換球員，各支球隊均被視為使用了1次替換球員機會。一支球隊在同一次比賽暫停期間替換多名球員僅算作使用了1次替換球員機會) ；
 - 10.3 中場休息時可有額外替換球員機會。
 - 10.4 若比賽需進入加時賽，每支球隊替換球員安排如下：
 - 10.4.1 如果尚未全數使用其替換球員名額和 / 或替換球員機會，則餘下的替換球員名額和替換球員機會均可在加時比賽使用；
 - 10.4.2 每支球隊在加時比賽時可有1名額外的球員替換名額及有1次額外的替換球員機會；
 - 10.4.3 於法定比賽完結後和加時比賽開始前、或加時比賽的中場休息時進行替換球員，有關替換不會被視為使用了一次替換機會。
 - 10.5 本賽事將根據球例引入額外永久替換腦震盪球員的安排，當球隊的醫療人員向裁判員表示受傷球員的情況為發生或懷疑腦震盪，該球隊即可使用1次「替換腦震盪球員」名額，當該球隊使用了「替換腦震盪球員」的名額，對方球隊亦可選擇以任何理由使用1次「額外替換球員名額」。有關安排將依照球例執行。



11. 中國香港足球總會有權因應參賽球隊數目或因特殊原因而修改賽制，並保留隨時修改賽制之權利。
12. 如遇球隊退出賽事，該球隊已完成比賽之比賽紀錄將不受影響，餘下比賽則根據賽程繼續進行。

比賽場地及賽期

13. 中國香港足球總會負責安排所有比賽場地。
14. 中國香港足球總會將會負責編定賽事中的賽程，所有參賽球隊必須按照賽程出賽。賽程表中的比賽資料，包括但不限於比賽日期、開賽時間、比賽場地、主隊（先列出）、客隊（後列出）。中國香港足球總會將在球季展開前向各參賽球會公佈有關賽程。中國香港足球總會將保留權力於賽程上作出改動。

比賽用球及裝備章則

15. 中國香港足球總會保留有關指定比賽用球條款的權利。
16. 參賽球隊必須嚴格遵守中國香港足球總會裝備章則。

球員資格

17. 同一名球員只能在同一球季為一間球會參加本賽事。（以出場作賽為準，如球員只列出賽名單上但未有正式出場作賽則不作計算）

獎盃及獎牌

18. 足總盃屬中國香港足球總會產業。
19. 冠軍球隊將會獲頒足總盃，並需要在2026/27足總盃舉行最後一場比賽的兩個月前，以良好狀態歸還予中國香港足球總會。於保留足總盃期間，若足總盃有任何損壞，中國香港足球總會將保留對該冠軍球隊追索相關維修費用之權力。
20. 冠軍球隊將會獲頒一座複製獎盃予以保留，另加45面紀念獎牌。
21. 亞軍球隊將會獲頒45面紀念獎牌。
22. 決賽最佳球員獲頒發獎盃1座。



違反章則處理方法

23. 假如任何參賽球會及其球隊職員、球員違反本章則或其他不檢行為，本會將交由紀律及道德委員會處理。

語言

24. 如在本章則的英文或中文版本之中，在理解上有任何差異，則以中文版本為最終依歸。

修改及解釋條文

25. 本會董事會有權隨時修改、增刪及解釋本賽制修改之任何條文。

-- 完 --



Name of the Competition

1. The Competition shall be officially called the “2025/26 FA Cup”. The Football Association of Hong Kong, China Limited (hereinafter referred to as the “HKFA”) reserves the rights to add the name of the Title Sponsor or to change the entire competition name into the name of the Title Sponsor.

Governance of the Competition

2. The FA Cup shall be wholly governed by HKFA.

General Provisions

3. Unless otherwise stated in these Regulations, 2025/26 Hong Kong Premier League Competition Regulations shall apply.
4. Unless otherwise stated in these Regulations, the current HKFA Constitution, rules, regulations, codes, guidelines, circulars or directives in force at the time of the Competition are binding for all parties participating and involving in the Competition (including but not limited to the players, team officials, referees or competition staff, etc).

Club Entry & Participation

5. The participating teams of 2025/26 Hong Kong Premier League shall participate in FA Cup. Each participating club shall not send more than one team to participate. The HKFA Board has the right to invite local or foreign teams to participate in the Competition.
6. With the approval of at least two-thirds of attending directors, the HKFA Board may reject the application filed by any team for participation in the Competition.

Playing Format and Related Arrangement

7. Each participating team shall send its best team to play. Otherwise, it shall submit a report specifying the reason to the Secretariat of HKFA.
8. The FA Cup will be played under single knockout format. The participating teams shall be drawn to play each other by lot drawing while the teams that advanced to the semi-finals of the 2024/25 FA Cup will be the seeded teams and will directly advance to the second round of the FA Cup.

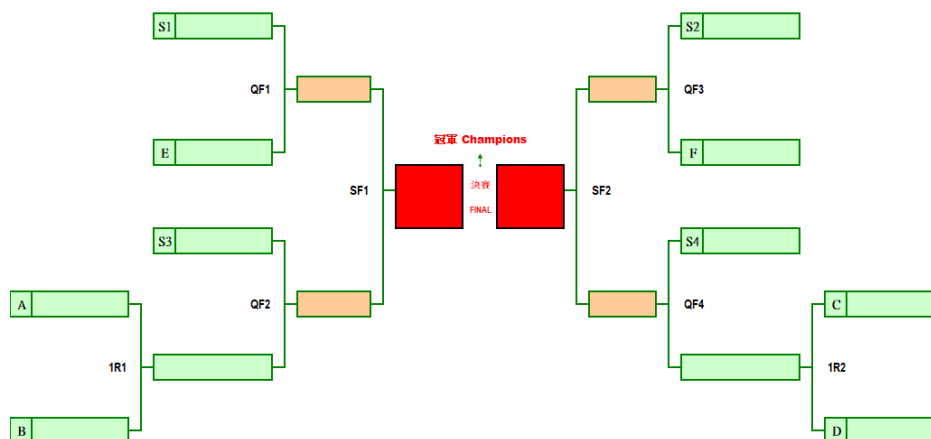



9. Each Match shall last ninety (90) minutes, comprising two (2) periods of forty-five (45) minutes, with a half-time interval of fifteen (15) minutes. When a match ends in a tie after completion of the 90-minute period, the match shall go into extra time which is comprising two (2) periods of fifteen (15) minutes. If the result is still draw, a penalty shoot-out as defined in the Laws of the Game will be applied to determine the winner of the match.
10. The Competition shall allow each playing team to nominate up to twelve (12) substitutes in a match.

The substitution arrangement will be applied as follows:

During the match, each team:

- has a maximum of five substitutes
- has a maximum of three substitution opportunities*
- may additionally make substitutions at half-time

Where extra time is played, each team:

- may use an additional substitute (whether or not the team has used its maximum number of substitutes)
- has one additional substitution opportunity* (whether or not the team has used its maximum number of substitution opportunities)
- may additionally make substitutions:
 - in the period between full-time and the start of extra time
 - at half-time in extra time
- If a team has not used its maximum number of substitutes or substitution opportunities, the unused substitutions and opportunities may be used in extra time.

* Where both teams make a substitution at the same time, this will count as a used substitution opportunity for each team. Multiple substitutions by a team during the same stoppage in play count as one used substitution opportunity.

According to the IFAB Law of The Game, the Competition shall implement the "Additional Permanent Concussion Substitutions Protocol". Please refer to the article for the principles and procedures.

11. HKFA has the right to change or alter the competition system based on the number of participating teams or other special reasons and reserves the right to modify the competition system if necessary.
12. If any team withdraws from the Competition, the completed match record will not be affected and the remaining match schedule will continue according to the fixture.

Match Venue and Fixture

13. HKFA is responsible for the venue arrangement.
14. HKFA shall be responsible for drawing up the fixtures of the Competition and the Participating Clubs shall play in all their matches so arranged. The fixture list containing match information including but not limited to: the dates, kick-off times, venues, Home Teams (first-named) and Visiting Teams (last-named) shall be disseminated by HKFA to participating clubs before the commencement of a season as soon as it is fixed. The fixture may change at the discretion of the HKFA.



Match Balls and Equipment Regulations

26. HKFA reserves right of ball deals and provide the official balls for matches.
27. All participating clubs in the Competition shall comply strictly with the HKFA Equipment Regulations in force at the time of the Competition.

Eligibility of Players

28. The same player shall only participate in this Competition for one club in the same season. (The player who is fielded in the match will be counted as participation. It will not be counted as participation if the player is only listed in the start list but not be fielded in the match)

Trophy and Medal

29. The FA Cup trophy is the property of HKFA.
30. The Champion shall receive the FA Cup trophy, and the trophy shall return to HKFA in good condition two months before the final match of 2025/26 FA Cup. HKFA reserves the right to recourse to the champion team for related repair costs if the trophy is damaged during the retention period.
31. The Champion shall be awarded a replica of the trophy for retention, and forty-five (45) commemorative medals
32. The Runners-up shall be awarded forty-five (45) medals
33. The player of the match in the final shall be awarded a trophy.

Violation of the Regulations

34. If any participating club and its team officials or players violate these Regulations or other misconduct, the relevant matter will be referred to the Disciplinary & Ethics Committee for handling.

Languages

35. In the case of any discrepancy in the interpretation of the English and Chinese version of these Regulations, the Chinese version shall be authoritative.

Amendment and Interpretation of the Regulations

36. HKFA Board shall have the right to make amendments, additions, deletions and to interpret any articles in these Regulations.

-- End --



FA CUP



1974/1975 Seiko	1991/1992 Ernest Borel	2008/2009 Tai Po
1975/1976 Seiko	1992/1993 Eastern	2009/2010 TSW Pegasus
1976/1977 Rangers	1993/1994 Eastern	2010/2011 South China
1977/1978 Seiko	1994/1995 Rangers	2011/2012 Kitchee
1978/1979 Yuen Long	1995/1996 South China	2012/2013 Kitchee
1979/1980 Seiko	1996/1997 Instant-Dict.	2013/2014 Eastern
1980/1981 Seiko	1997/1998 Instant-Dict.	2014/2015 Kitchee
1981/1982 Bulova	1998/1999 South China	2015/2016 Hong Kong Pegasus
1982/1983 Bulova	1999/2000 Happy Valley	2016/2017 Kitchee
1983/1984 Eastern	2000/2001 Instant-Dict.	2017/2018 Kitchee
1984/1985 South China	2001/2002 South China	2018/2019 Kitchee
1985/1986 Seiko	2002/2003 Sun Hei	
1986/1987 South China	2003/2004 Happy Valley	
1987/1988 South China	2004/2005 Sun Hei	
1988/1989 Lai Sun D' Flower	2005/2006 Sun Hei	
1989/1990 South China	2006/2007 South China	
1990/1991 South China	2007/2008 Citizens	



FA CUP